



KOMO®
Product certificate
K96132/02



Issued 2019-09-02 Replaces K96132/01
Valid until *undefined* D.d. 2017-12-01
Page 1 of 2

Steel for the reinforcement of concrete B500A: welded fabrics
Thy-Marcinelle S.A.

STATEMENT BY KIWA

This product certificate is, issued on the basis of BRL 0501 "Steel for the reinforcement of concrete" (Betonstaal), dated 01 September 2010, including amendment sheet dated December 12, 2018 in accordance with the Kiwa-Regulations for Certification.

The quality system and product characteristics in association with Steel for the reinforcement of concrete are assessed periodically.

On this basis Kiwa declares that a justified confidence exists, that the Steel for the reinforcement of concrete delivered by the certificate holder at delivery fulfill:

- the technical specification laid down in this product certificate,
 - the product requirements as laid down in this product certificate and in the BRL.
- provided that Steel for the reinforcement of concrete have been marked with the KOMO®-mark in a manner as indicated in this product certificate;

Ronald Karel
Kiwa

*This product certificate is listed in the overview on the website of Stichting KOMO: www.komo.nl.
Advise: consult www.kiwa.nl to determine whether this product certificate is valid.*

Kiwa Nederland B.V.
Sir Winston Churchilllaan 273
Postbus 70
2280 AB RIJSWIJK
Tel. 088 998 44 00
Fax 088 998 44 20
info@kiwa.nl
www.kiwa.nl

Certificate holder
Thy-Marcinelle S.A.
Rue de l'Acier, 1
6000 CHARLEROI
BELGIË
Tel. + 32 71270111
laboratoire.tm@rivagroup.com



Evaluated is:
quality system
product
Periodic inspection

Steel for the reinforcement of concrete B500A (welded fabrics)

TECHNICAL SPECIFICATION

Subject

Steel for the reinforcement of concrete B500A (welded fabrics)

The products are in accordance with the requirements of chapter 4 of guideline BRL 0501 and with that of NEN 6008. The products are meant to be used in constructions of concrete.

Product characteristics

Classification :B500A
 Production method :Cold profiled
 Nominal size :5 – 6 – 7 – 8 – 10 and 12 mm
 Delivery condition :welded fabrics

Marking

The products are marked with a label with upon it at least on a clear and indelible way:

- the KOMO[®]-logo and the certificate number, figure 1;
- the classification B500A;
- the diameter;
- the rolling mark;
- heatnumber/castnumber/coilnumber;
- name of the certificate holder;
- BRL 0501.

Place of the label: at least one label per package of welded fabrics.

Steel for the reinforcement of concrete is marked on the following way:

On one rib row by missing ribs, with the code (2-15), figure 2.

Place of the mark: on a mutual distance of ± 0,50 meter. The position of the transverse ribs may also be in reverse.

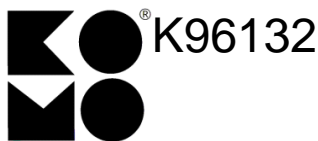
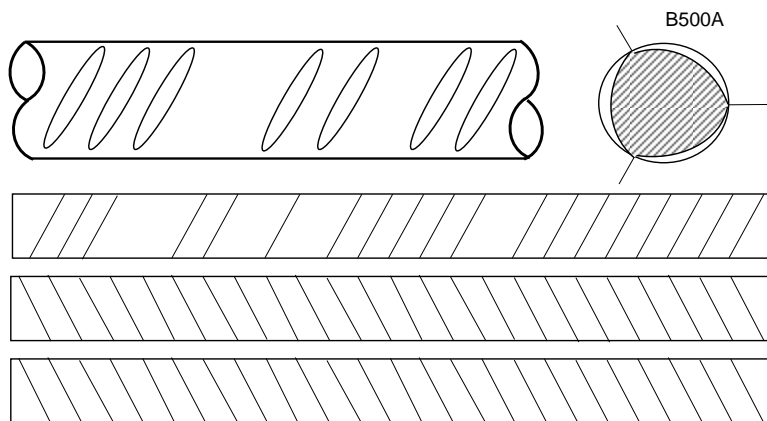

Figure 1



(2-15) Figure 2

RECOMMENDATIONS FOR CUSTOMERS

Check at the time of delivery whether:

- the supplier has delivered in accordance with the agreement;
- the mark and the marking method are correct;
- the products show no visible defects as a result of transport etc.

If you should reject a product on the basis of the above, please contact:

- Thy-Marcinelle S.A.

and, if necessary,

- Kiwa Nederland B.V.

Consult for the proper storage, transport and processing NEN-EN 13670.

LIST OF DOCUMENTS

NEN 6008 :Betonstaal
 NEN-EN 13670 :Het vervaardigen van betonconstructies

* For the actual version of the standards see the latest version of the BRL 0501 or latest amendment sheet.